

Inline filters with filter element according to DIN 24550

Type 245LEN0040 to 0400; 245LE0130, 0150

RE 51421

Edition: 2021-04

Replaces: -



- ▶ Size according to **DIN 24550**: 0040 to 0400
- ▶ additional sizes: 0130, 0150
- ▶ Nominal pressure 250 bar [3628 psi]
- ▶ Connection up to G1 1/2; SAE 1 1/2; SAE 24
- ▶ Operating temperature: -10 °C to +100 °C [+14 °F to +212 °F]

Features

Inline filters are used in hydraulic systems for separating solid materials from fluids and lubricating oils. They are intended for attachment in pipelines.

They distinguish themselves by the following:

- ▶ Filters for inline installation
- ▶ Special highly efficient filter materials
- ▶ Filtration of very fine particles and high dirt holding capacity across a broad pressure differential range
- ▶ High collapse resistance of the filter elements
- ▶ By default equipped with mechanical optical maintenance indicator with memory function
- ▶ Various, optional electronic switching elements, modular design
- ▶ Optional bypass valve integrated in the filter housing
- ▶ High filtration performance due to the tangential cyclone-effect flow path

Contents

Features	1
Ordering code filter	2, 3
Preferred types	4
Ordering code accessories	5
Filter design	6
Symbols	7
Function, section	8
Technical data	9, 10
Compatibility with permitted hydraulic fluids	10
Dimensions	11, 12
Maintenance indicator	13
Ordering code spare parts	14 ... 16
Assembly, commissioning, maintenance	17
Tightening torques	18
Directives and standardization	18, 19

Ordering code filter

01	02	03	04	05	06	07	08	09
245LE	N		-			-	-	

Series

01	Inline filter 250 bar [3628 psi]	245LE
----	----------------------------------	-------

Filter element

02	With filter element according to DIN 24550	N
----	---	---

Size

03	LEN...	0040 0063 0100 0160 0250 0400
	LE...	0130 0150

Filter rating in μm

04	Absolute (ISO 16889; $\beta_x(c) \geq 200$)	Glass fiber material, not cleanable	PWR3 PWR6 PWR10 PWR20
	Nominal	Stainless steel wire mesh, cleanable	G10 G25 G40 G60 G100

Pressure differential

05	Max. admissible pressure differential of the filter element 30 bar [435 psi] – Filter with bypass valve	A00
	Max. admissible pressure differential of the filter element 330 bar [4786 psi] – Filter without bypass valve	B00

Maintenance indicator

06	Maintenance indicator, mech./optical, switching pressure 2.2 bar [31.9 psi] – bypass cracking pressure 3.5 bar [51 psi]	V2.2
	Maintenance indicator, mech./optical, switching pressure 5.0 bar [72.5 psi] – bypass cracking pressure 7.0 bar [101 psi]	V5.0

Seal

07	NBR seal	M
	FKM seal	V

Ordering code filter

01	02	03	04	05	06	07	08	09
245LE	N		-		-	-	-	-

Connection

08	Frame size		0040	0063-0100	0130-0150	0160-0400	
	Connection						
	G1/2	Pipe thread according to ISO 228	●	X			R2
	G3/4		X	X			R3
	G1		X	●	X		R4
	G1 1/4				●	X	R5
	G1 1/2				X	●	R6
	SAE 1 1/2"	SAE flange 6,000 psi				X	S6
	SAE 10	Pipe thread according to SAE J1926	X				U3
	SAE 12			X			U4
	SAE 20				X		U5
	SAE 24					X	U6
			●	Standard connection			
			X	Alternative connection			

Supplementary information

09	Manufacturer's inspection certificate M according to DIN 55350 T18	Z1
----	--	----

Order example:

245LEN0100-PWR10A00-V5,0-M-R4

Further versions (filter materials, connections,...) are available on request.

Preferred types

245LE(N) preferred types, NBR seal, flow specifications for 30 mm²/s [143 SUS]

Inline filter with bypass, filter rating 3 µm

Type	Flow in l/min [gpm] at $\Delta p = 1.5 \text{ bar}$ [21.75 psi] ¹⁾	Material no. Filter				Material no. Replacement element
245LEN0040-PWR3A00-V5,0-M-..	29 [6.1]	..R2	R928030024	..U3	R928030216	R928006645
245LEN0063-PWR3A00-V5,0-M-..	44 [7.9]	..R4	R928030025	..U4	R928030217	R928006699
245LEN0100-PWR3A00-V5,0-M-..	61 [11.6]	..R4	R928030026	..U4	R928030218	R928006753
245LE0130-PWR3A00-V5,0-M-..	101 [19.5]	..R5	R928030027	..U5	R928030219	R928022274
245LE0150-PWR3A00-V5,0-M-..	123 [23.5]	..R5	R928030028	..U5	R928030220	R928022283
245LEN0160-PWR3A00-V5,0-M-..	184 [34.9]	..R6	R928030029	..U6	R928030221	R928006807
245LEN0250-PWR3A00-V5,0-M-..	261 [50.2]	..R6	R928030030	..U6	R928030222	R928006861
245LEN0400-PWR3A00-V5,0-M-..	330 [66.0]	..R6	R928030031	..U6	R928030223	R928006915

Inline filter with bypass, filter rating 6 µm

Type	Flow in l/min [gpm] at $\Delta p = 1.5 \text{ bar}$ [21.75 psi] ¹⁾	Material no. Filter				Material no. Replacement element
245LEN0040-PWR6A00-V5,0-M-..	48 [12.7]	..R2	R928030280	..U3	R928030472	R928006646
245LEN0063-PWR6A00-V5,0-M-..	78 [20.6]	..R4	R928030281	..U4	R928030473	R928006700
245LEN0100-PWR6A00-V5,0-M-..	82 [21.7]	..R4	R928030282	..U4	R928030474	R928006754
245LE0130-PWR6A00-V5,0-M-..	152 [40.2]	..R5	R928030283	..U5	R928030475	R928022275
245LE0150-PWR6A00-V5,0-M-..	170 [45.0]	..R5	R928030284	..U5	R928030476	R928022284
245LEN0160-PWR6A00-V5,0-M-..	245 [64.7]	..R6	R928030285	..U6	R928030477	R928006808
245LEN0250-PWR6A00-V5,0-M-..	310 [81.9]	..R6	R928030286	..U6	R928030478	R928006862
245LEN0400-PWR6A00-V5,0-M-..	400 [105.7]	..R6	R928030287	..U6	R928030479	R928006916

Inline filter with bypass, filter rating 10 µm

Type	Flow in l/min [gpm] at $\Delta p = 1.5 \text{ bar}$ [21.75 psi] ¹⁾	Material no. Filter				Material no. Replacement element
245LEN0040-PWR10A00-V5,0-M-..	58 [15.3]	..R2	R928030536	..U3	R928030728	R928006647
245LEN0063-PWR10A00-V5,0-M-..	98 [18.2]	..R4	R928030537	..U4	R928030729	R928006701
245LEN0100-PWR10A00-V5,0-M-..	84 [22.2]	..R4	R928030538	..U4	R928030730	R928006755
245LE0130-PWR10A00-V5,0-M-..	172 [45.4]	..R5	R928030539	..U5	R928030731	R928022276
245LE0150-PWR10A00-V5,0-M-..	196 [51.8]	..R5	R928030540	..U5	R928030732	R928022285
245LEN0160-PWR10A00-V5,0-M-..	281 [74.2]	..R6	R928030541	..U6	R928030733	R928006809
245LEN0250-PWR10A00-V5,0-M-..	330 [87.2]	..R6	R928030542	..U6	R928030734	R928006863
245LEN0400-PWR10A00-V5,0-M-..	420 [111.0]	..R6	R928030543	..U6	R928030735	R928006917

¹⁾ An appropriate differential pressure via the filter and measuring device according to ISO 3968. The differential pressure measured on the maintenance indicator is lower.

Ordering code accessories

(dimensions in mm [inch])

Electronic switching element for maintenance indicators

01	02	03
WE	-	-

Maintenance indicator

01	Electronic switching element	WE
----	------------------------------	-----------

Type of signal

02	1 switching point	1SP
	2 switching points, 3 LED	2SP
	2 switching points, 3 LED and signal suppression up to 30 °C [86 °F]	2SPSU

Connector

03	Round plug-in connection M12 x 1, 4-pole	M12 x 1
	Rectangular plug-in connection, 2-pole, design A according to EN-175301-803	EN175301-803

Material numbers of the electronic switching elements

Material no.	Type	Signal	Switching points	Connector	LED
R928028409	WE-1SP-M12 x 1	Changeover	1	M12 x 1	without
R928028410	WE-2SP-M12 x 1	Normally open (at 75%) / normally closed contact (at 100%)	2		M12 x 1
R928028411	WE-2SPSU-M12 x 1				
R928036318	WE-1SP-EN175301-803	Normally closed contact	1	EN 175301-803	without

Mating connectors

for electronic switching element with round plug-in connection M12 x 1

Mating connector suitable for K24 4-pole, M12 x 1 with screw connection, cable gland Pg9.

Material no. R900031155

Mating connector suitable for K24-3m 4-pole, M12 x 1 with potted-in PVC cable, 3 m long.

Line cross-section: 4 x 0.34 mm²

Core marking: **1** brown **2** white
 3 blue **4** black

Material no. R900064381

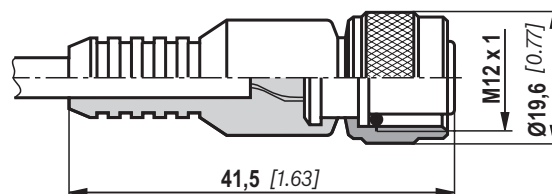
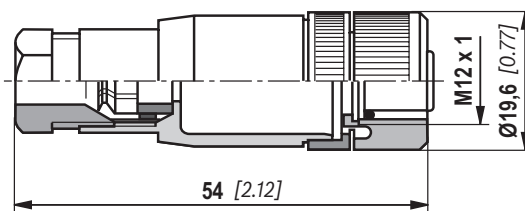

For more round plug-in connections and technical data refer to data sheet 08006.

Order example:

Inline filter with mechanical optical maintenance indicator for $p_{nom.} = 250 \text{ bar}$ [3628 psi] with bypass valve, size 0100, with filter element 10 µm and electronic switching element M12x1 with 1 switching point for hydraulic fluid mineral oil HLP according to DIN 51524.

Filter with mech. optical maintenance indicator: 245LEN0100-PWR10A00-V5,0-M-R4

Material no. R928030538

Switching element: WE-1SP-M12 x 1

Material no. R928028409

Mating connector: Mating connector suitable for K24 4-pole, M12 x 1 with screw connection, cable gland Pg9.

Material no. R900031155

Filter design

Easy selection of the filter size is made possible by the FilterSelect online tool. The filter can be designed using the operating pressure, flow and fluid system parameters. The required filter rating is based on the application, the sensitivity to contamination of the components and the environmental conditions.

The program leads you through the menu on a step-by-step basis.

A documentation of the filter selection can finally be created in the form of a PDF file. This file contains the entered parameters, the designed filter with material number including spare parts, and the pressure loss curves.

Link FilterSelect:

<http://www.filterselect.de>

Other languages can be selected using the page navigation.

standard search

application: hydraulics for industrial use and applications with lubricating oil

Product category: please select

type: please select

pressure range: please select

filter material: please select

fineness: please select

volume flow rate: [l/min]

viscosity:
 * = working point

kin viscosity 1: [mm²/s]

search via type of medium full-text search medium

please select

please select

temp 1: [°C] [°F] kin viscosity 1: [mm²/s]

dyn. viscosity 1: [cP] density 1: [kg/dm³] kin viscosity 1: [mm²/s]

collapse pressure resistance according to ISO 2941: 30 bar

Symbols

Inline filter with bypass and mechanical indicator

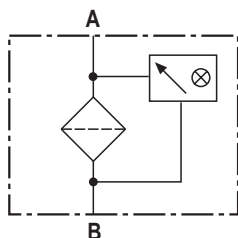
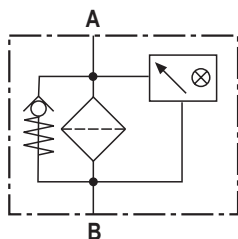

Inline filter without bypass and with mechanical indicator

Electronic switching element for maintenance indicator

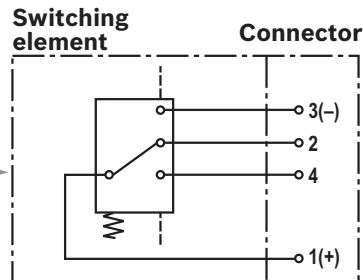

WE-1SP-M12 x 1

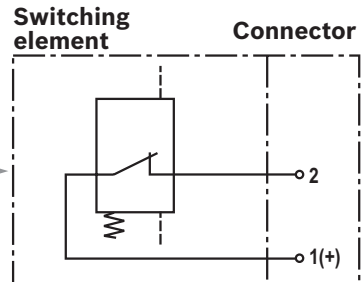

WE-1SP-EN175301-803

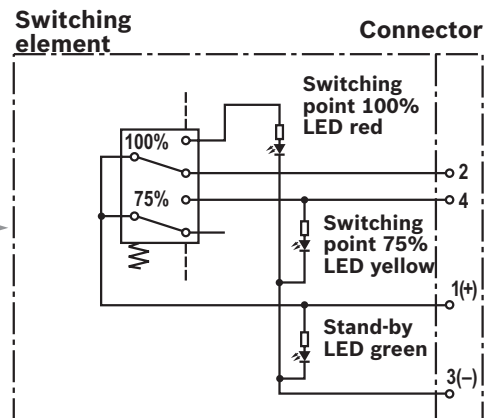

WE-2SP-M12 x 1

Circuit diagram drawn in plugged condition (operating state)

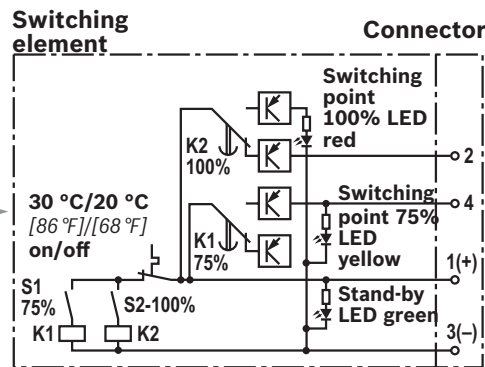

WE-2SPSU-M12 x 1

Circuit diagram drawn in plugged condition at temperature > 30 °C [86 °F] (operating condition)

Function, section

The 245LE(N) inline filter is suitable for inline installation. It basically consists of filter head (1), a screwable filter bowl (2), filter element (3) as well as mechanical optical maintenance indicator (4). In case of filters with low-pressure-differential-stable filter elements (= code letter pressure differential A), there is an assembled bypass valve (5) as standard.

Via the inlet, the fluid reaches the filter element (3) where it is cleaned. The dirt particles filtered out collect in the filter element (3). Via the outlet, the filtered fluid enters the hydraulic circuit.

The filter housing and all connection elements are designed so that pressure peaks - as they may e.g. occur in case of abrupt opening of large control valves due to the accelerated fluid quantity - can be securely absorbed. As of size 0160, the standard equipment comprises a drain screw (7).

By default, the filter is equipped with mechanical optical maintenance indicator (4). The electronic switching element (8) which has to be ordered separately is attached to the mechanical optical maintenance indicator (4) and held by means of a locking ring.

The electronic switching elements with 1 or 2 switching points are connected via a mating connector according to IEC-60947-5-2 or via a cable connection according to EN17301-803.

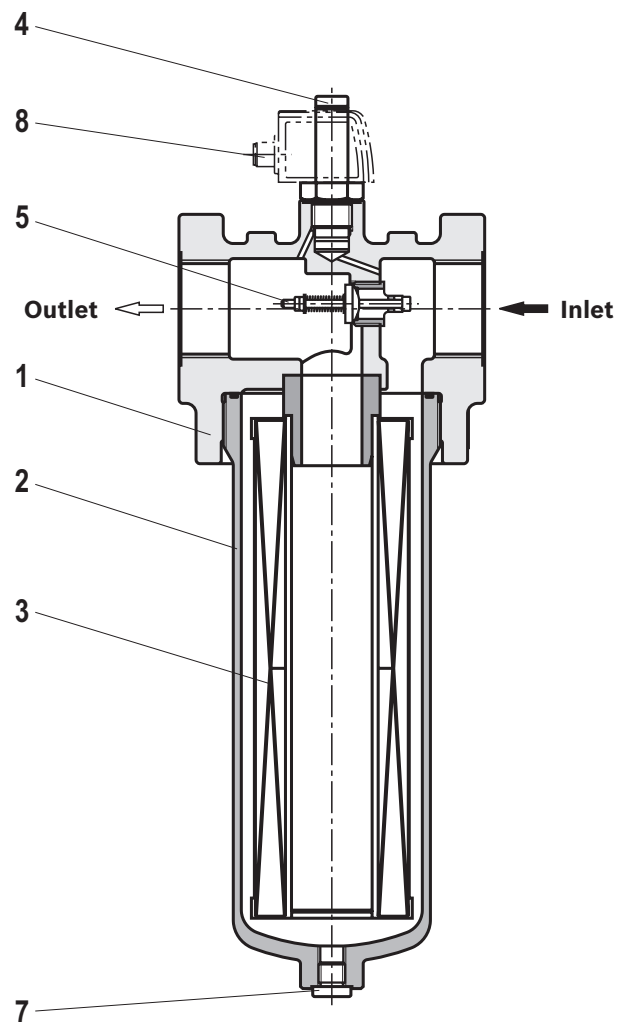

! WARNING!

- If the maintenance indicator is not observed while the element is exchanged, the bypass valve will open if the pressure differential increases. This means that part of the volume flow enters unfiltered into the clean side of the filter. Effective filtration is therefore no longer guaranteed.

Technical data

(For applications outside these parameters, please consult us!)

General						
Installation position		vertical				
Ambient temperature range		°C [°F]	-10 ... +65 [+14 ... +149]; (short periods down to -30 [-22])			
Storage conditions	- NBR seal	°C [°F]	40 ... +65 [-40 ... +149]; max. relative air humidity 65%			
	- FKM seal	°C [°F]	-20 ... +65 [-4 ... +149]; max. relative air humidity 65%			
Weight	- Filter	Size	0040	0063	0100	0130
		kg [lbs]	3.2 [7.10]	3.8 [8.40]	4.2 [9.30]	6.95 [15.30]
		Size	0150	0160	0250	0400
		kg [lbs]	7.25 [16]	11.5 [25.40]	12.2 [26.90]	13.8 [30.40]
	- Filter bowl	Size	0040	0063	0100	0130
		kg [lbs]	0.57 [1.26]	1.03 [2.27]	1.44 [3.17]	1.93 [4.25]
		Size	0150	0160	0250	0400
		kg [lbs]	2.27 [5.00]	2.49 [5.49]	3.33 [7.34]	4.72 [10.41]
Volume	Size	0040	0063	0100	0130	
		l [US gal]	0.21 [0.06]	0.38 [0.10]	0.53 [0.14]	0.76 [0.20]
	Size	0150	0160	0250	0400	
		l [US gal]	0.96 [0.25]	1.13 [0.30]	1.6 [0.42]	2.4 [0.63]
Material	- Filter head	GGG				
	- Filter bowl	Steel				
	- Bypass valve	PA6 / steel / POM				
	- Seals	NBR or FKM				
	- Optical maintenance indicator	Brass				
	- Electronic switching element	Plastic PA6				

Hydraulic			
Maximum operating pressure	bar [psi]	250 [3628]	
Hydraulic fluid temperature range	°C [°F]	-10 ... +100 [+14 ... +212]	
Minimum conductivity of the medium	pS/m	300	
Fatigue strength according to ISO 10771 ¹⁾	Load cycles	> 10 ⁶ with max. operating pressure	
Type of pressure measurement of the maintenance indicator	Pressure differential		
Assignment: Response pressure of the maintenance indicator / cracking pressure of the bypass valve	Response pressure of the maintenance indicator	Cracking pressure of the bypass valve	
	bar [psi]	2.2 ± 0.3 [31.9 ± 4.4]	3.5 ± 0.35 [50.8 ± 5.1]
	bar [psi]	5.0 ± 0.5 [72.5 ± 7.3]	7.0 ± 0.5 [101.5 ± 7.3]
Filtration direction	From the outside to the inside		

¹⁾ The service life of the components is e.g. influenced by:

- ▶ The individual load frequency of the application
- ▶ The actually occurring pressure increase rate

The technical specifications apply complying with the specified performance limits. Extended operational resistance/load change upon request.

Technical data

(For applications outside these parameters, please consult us!)

Electric (electronic switching element)				
Electrical connection	Round plug-in connection M12 x 1, 4-pole			Standard connection EN 175301-803
	Version	WE-1SP- M12 x 1	WE-2SP- M12 x 1	WE-2SPSU- M12 x 1
Contact load, direct voltage	$A_{max.}$	1		
Voltage range	$V_{max.}$	150 (AC/DC)	10 ... 30 (DC)	250 (AC)/200 (DC)
Max. switching power with resistive load	W	20		70
Switching type	- 75% signal	-	Normally open contact	
	- 100% signal	Changeover	Normally closed contact	
	- 2SPSU			Signal interconnection at 30 °C [86 °F], return switching at 20 °C [68 °F]
Display via LEDs in the electronic switching element 2SP..		Stand-by (LED green); 75% switching point (LED yellow) 100% switching point (LED red)		
Protection class according to EN 60529	IP	67		65
Ambient temperature range	°C [°F]	-25 ... +85 [-13 ... +185]		
For direct voltage above 24 V, spark extinguishing is to be provided for protecting the switching contacts.				
Weight	- electronic switching element	kg [lbs]	0.1 [0.22]	

Filter element				
Glass fiber material PWR..		Single-use element on the basis of inorganic fiber		
		Filtration ratio according to ISO 16889 up to $\Delta p = 5 \text{ bar [72.5 psi]}$	Achievable oil cleanliness accord- ing to ISO 4406 [SAE-AS 4059]	
Particle separation	PWR20	$\beta_{20(c)} \geq 200$	19/16/12 ... 22/17/14	
	PWR10	$\beta_{10(c)} \geq 200$	17/14/10 ... 21/16/13	
	PWR6	$\beta_{6(c)} \geq 200$	15/12/10 ... 19/14/11	
	PWR3	$\beta_{5(c)} \geq 200$	13/10/8 ... 17/13/10	
Admissible pressure differential	- A00	bar [psi]	30 [435]	
	- B00	bar [psi]	330 [4785]	

Compatibility with permitted hydraulic fluids

Hydraulic fluid	Classification	Suitable sealing materials	Standards
Mineral oil	HLP	NBR	DIN 51524
Biodegradable	- insoluble in water	HETG	VDMA 24568
		HEES	
	- soluble in water	HEPG	VDMA 24568
Flame-resistant	- water-free	HFDU, HFDR	VDMA 24317
	- containing water	HFAS	DIN 24320
		HFAE	
	HFC	NBR	VDMA 24317

**Important information on hydraulic fluids!**

- ▶ For more information and data on the use of other hydraulic fluids, please refer to data sheet 90220 or contact us!
- ▶ **Flame-resistant – containing water:** Due to possible chemical reactions with materials or surface coatings of machine and system components, the service life with these hydraulic fluids may be less than expected.

Filter materials made of filter paper (P) may not be used, filter elements with glass fiber material have to be used instead.

- ▶ **Biodegradable:** If filter materials made of filter paper are used, the filter life may be shorter than expected due to material incompatibility and swelling.

Dimensions: 245LE(N) NG0040 ... NG0400
 (Dimensions in mm [inch])

Pipe thread connections
 UNF thread

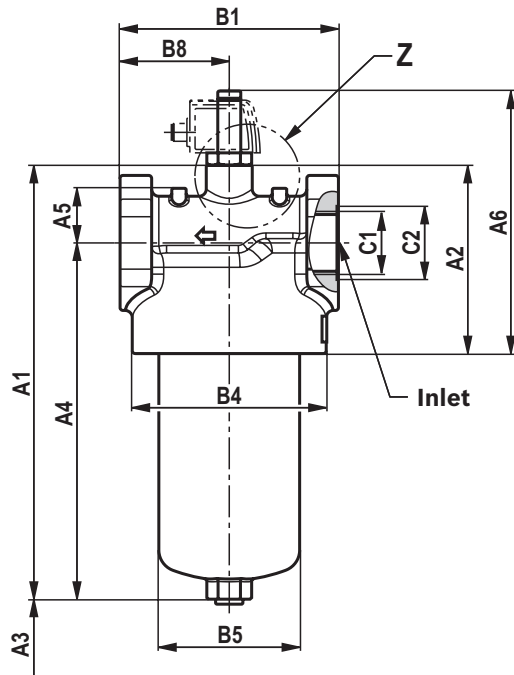

Connection SAE 1 1/2"
 - 3000 psi

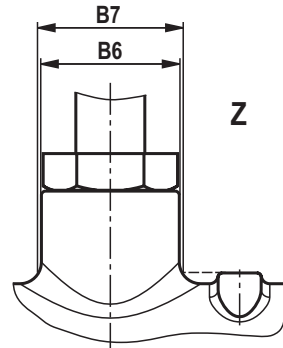
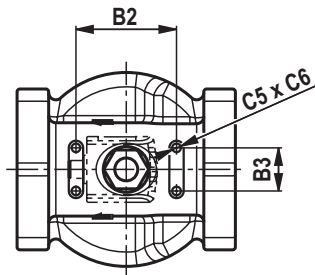
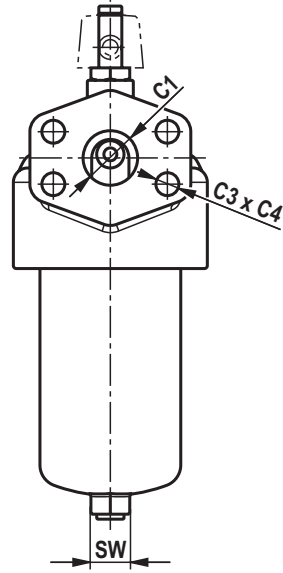

Dimensions: NG0040 ... NG0400(Dimensions in mm [*inch*])

Type	A1	A2	A3 ¹⁾	A4	A5	A6
245LEN0040	200 [7.87]	94 [3.70]	120 [4.72]	156 [6.14]	25 [0.98]	146 [5.75]
245LEN0063	264 [10.39]			220 [8.66]		
245LEN0100	354 [13.94]			310 [12.20]		
245LE0130	324 [12.76]	121 [4.76]	140 [5.51]	270 [10.63]	38 [1.50]	173 [6.81]
245LE0150	374 [14.72]			320 [12.60]		
245LEN0160	356 [14.02]	131 [5.16]	120 [4.72]	302 [11.89]		183 [7.20]
245LEN0250	392 [15.43]			338 [13.31]		
245LEN0400	542 [21.34]			488 [19.21]		

Type	B1 ²⁾	B2	B3	ØB4	ØB5	ØB6	ØB7	B8
245LEN0040	92 [3.62]	60 [2.36]	25 [0.98]	85 [3.35]	55 [2.17]	32 [1.26]	34 [1.34]	46 [1.81]
245LEN0063								
245LEN0100								
245LE0130	122 [4.80]	80 [3.15]	30 [1.18]	116 [4.57]	77 [3.03]		32 [1.26]	61 [2.40]
245LE0150								
245LEN0160	152 [5.98]	70 [2.76]		135 [5.31]	98 [3.86]			
245LEN0250								
245LEN0400								

Type	C1 connection					C3	C4	C5	C6	SW
	Standard R...	ØC2	Optional U...	ØC2	Optional S...					
245LEN0040	G1/2	28 [1.10]	SAE 10 7/8-14 UNF-2B	41 [1.61]	-	M16	22 [0.87]	M6	8 [0.31]	19 [0.75]
245LEN0063	G1	41 [1.61]	SAE 12 1 1/16-12 UN-2B							
245LEN0100										
245LE0130	G1 1/4	51 [2.01]	SAE 20 1 5/8-12 UN-2B	58 [2.28]	SAE 1 1/2" 3000 psi					24 [0.94]
245LE0150										
245LEN0160	G1 1/2	56 [2.20]	SAE 24 1 7/8-12 UN-2B	65 [2.56]	27 [1.06]					
245LEN0250										
245LEN0400										

1) Servicing height for filter element exchange

2) Dimension B1 is reduced with SAE flanges by 4 mm [0.16 inch]

Maintenance indicator (dimensions in mm [inch])

Pressure differential indicator with mounted switching element M12 x 1

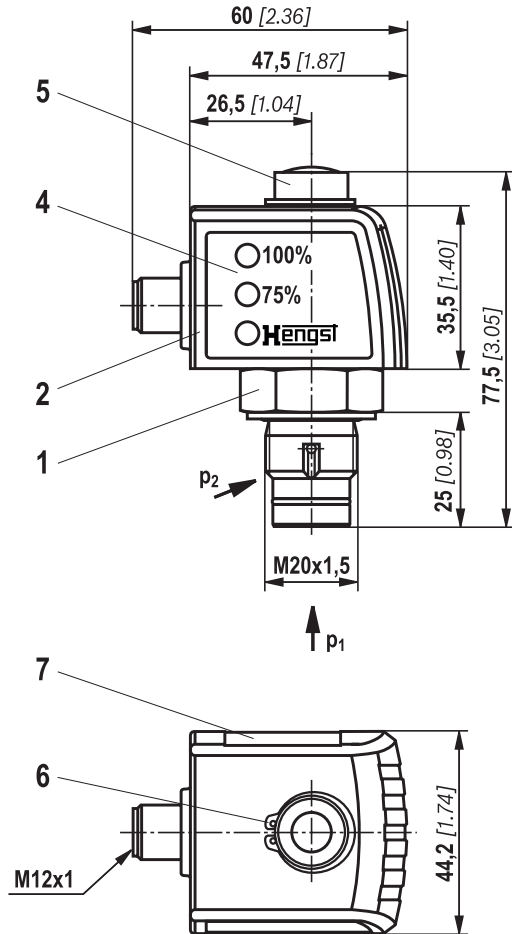

Pressure differential indicator with mounted switching element EN-175301-803

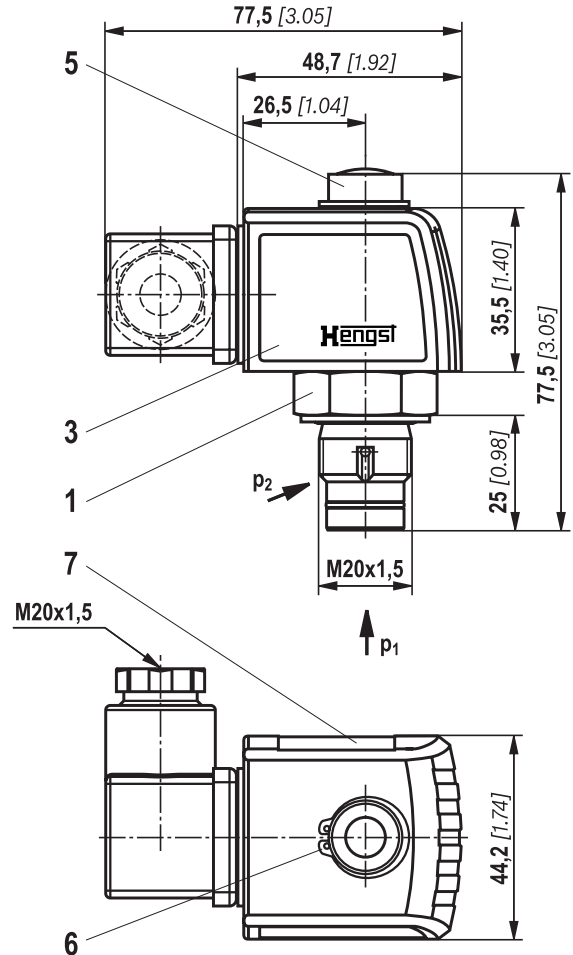

- 1 Mechanical optical maintenance indicator; max. tightening torque $M_{A \max} = 50 \text{ Nm}$ [36.88 lb-ft]
- 2 Switching element with locking ring for electrical maintenance indicator (rotatable by 360°); round plug-in connection M12 x 1, 4-pole
- 3 Switching element with locking ring for electrical maintenance indicator (rotatable by 360°); rectangular plug-in connection EN175301-803
- 4 Housing with three LEDs: 24 V =
green: Stand-by
yellow: Switching point 75%
red: Switching point 100%
- 5 Visual indicator bistable
- 6 Locking ring DIN 471-16 x 1, **material no. R900003923**
- 7 Name plate

Notices:

Representation contains mechanical optical maintenance indicator (1) and electronic switching element (2) (3).

Ordering code spare parts

Filter element

01	02	03	04	05	06
2.			-	-	0

Filter element

01	Design	2.
----	--------	----

Size

02	LEN...	0040 0063 0100 0160 0250 0400
	LE...	0130 0150

Filter rating in μm

03	Absolute (ISO 16889; $\beta_x(c) \geq 200$)	Glass fiber material, not cleanable	PWR3 PWR6 PWR10 PWR20
	Nominal	Stainless steel wire mesh, cleanable	G10 G25 G40 G60 G100

Pressure differential

04	Max. admissible pressure differential of the filter element 30 bar [435 psi] – Filter with bypass valve	A00
	Max. admissible pressure differential of the filter element 330 bar [4786 psi] – Filter without bypass valve	B00

Bypass valve

05	without bypass valve	0
----	-----------------------------	---

Seal

06	NBR seal	M
	FKM seal	V

Order example:

2,0100 PWR3-A00-0-M

For detailed information on Hengst filter elements please refer to data sheet 51420.

Preferred program replacement filter element

Replacement filter element 3 micron		Replacement filter element 6 micron		Replacement filter element 10 micron	
R928006645	2,0040 PWR3-A00-0-M	R928006646	2,0040 PWR6-A00-0-M	R928006647	2,0040 PWR10-A00-0-M
R928006699	2,0063 PWR3-A00-0-M	R928006700	2,0063 PWR6-A00-0-M	R928006701	2,0063 PWR10-A00-0-M
R928006753	2,0100 PWR3-A00-0-M	R928006754	2,0100 PWR6-A00-0-M	R928006755	2,0100 PWR10-A00-0-M
R928022274	2,0130 PWR3-A00-0-M	R928022275	2,0130 PWR6-A00-0-M	R928022276	2,0130 PWR10-A00-0-M
R928022283	2,0150 PWR3-A00-0-M	R928022284	2,0150 PWR6-A00-0-M	R928022285	2,0150 PWR10-A00-0-M
R928006807	2,0160 PWR3-A00-0-M	R928006808	2,0160 PWR6-A00-0-M	R928006809	2,0160 PWR10-A00-0-M
R928006861	2,0250 PWR3-A00-0-M	R928006862	2,0250 PWR6-A00-0-M	R928006863	2,0250 PWR10-A00-0-M
R928006915	2,0400 PWR3-A00-0-M	R928006916	2,0400 PWR6-A00-0-M	R928006917	2,0400 PWR10-A00-0-M

**Ordering code
spare parts**

Mechanical optical maintenance indicator

01	02	03	04	05	06
W	O	-	D01	-	-

01	Maintenance indicator	W
----	-----------------------	----------

02	Mechanical optical indicator	O
----	------------------------------	----------

Version

03	Pressure difference, modular design	D01
----	-------------------------------------	------------

Switching pressure

04	2.2 bar [32 psi]	2,2
	5.0 bar [72.5 psi]	5,0

Seal

05	NBR seal	M
	FKM seal	V

Max. operating pressure

06	Switching pressure 2.2 bar [32 psi], 450 bar [6527 psi]	450
	Switching pressure 5.0 bar [72.5 psi], 450 bar [6527 psi]	450

Mechanical optical maintenance indicator	Material no.
WO-D01-2.2-M-450	R928038783
WO-D01-2.2-V-450	R928038782
WO-D01-5,0-M-450	R901025313
WO-D01-5,0-V-450	R901066235

Ordering code spare parts

Seal kit

01 02 03 04

D	245LE		-	
----------	--------------	--	---	--

01	Seal kit	D
----	-----------------	----------

02	Series	245LE
----	---------------	--------------

Size

03	NG0040-0100	N0040-0100
	Size 0130-0150	0130-0150
	NG0160-0400	N0160-0400

Seal

04	NBR seal	M
	FKM seal	V

Material no.	Seal kit
R928028016	D245LEN0040-0100-M
R928028214	D245LE0130-0150-M
R928028017	D245LEN0160-0400-M
R928047988	D245LEN0040-0100-V
R928048951	D245LE0130-0150-V
R928039838	D245LEN0160-0400-V

Assembly, commissioning, maintenance

Installation

- ▶ The max. operating pressure of the system must not exceed the max. admissible operating pressure of the filter (see type plate).
- ▶ During assembly of the filter (see also chapter “Tightening torque”), the flow direction (direction arrows) and the required servicing height of the filter element (see chapter “Dimensions”) are to be considered.
- ▶ Easy filter element exchange is guaranteed in the installation position filter bowl vertically downwards. The maintenance indicator must be arranged so it is easily viewed in operation.
- ▶ Remove the plastic plugs in the filter inlet and outlet.
- ▶ Ensure that the system is assembled without tension stress.
- ▶ The optional electronic maintenance indicator is connected via the electronic switching element with 1 or 2 switching points, which is attached to the mechanical optical maintenance indicator and held by means of the locking ring.

Commissioning

- ▶ Commission the system.

 **Notice:**

There is no bleed function provided at the filter.

Maintenance

- ▶ If at operating temperature, the red indicator pin reaches out of the mechanical optical maintenance indicator and/or if the switching process in the electronic switching element is triggered, the filter element is contaminated and needs to be replaced and cleaned respectively.
More details see data sheet 51450
- ▶ The material number of the corresponding replacement filter element is indicated on the name plate of the complete filter. It must comply with the material number on the filter element.
- ▶ Decommission the system.
- ▶ The operating pressure is to be release on the system side.

 **Notice:**

There is no bleed function provided at the filter.

- ▶ Via the drain screw (from size 0160 fitted by default), the oil on the dirt side can be drained.
- ▶ Screw off the filter bowl.
- ▶ Remove the filter element from the spigot by rotating it slightly.
- ▶ Clean the filter components, if necessary.
- ▶ Check the seals at the filter bowl for damage and renew them, if necessary.
For suitable seal kits refer to chapter “Spare parts”.
- ▶ Filter elements made of wire mesh can be cleaned. For detailed cleaning instructions refer to data sheet 51420.
- ▶ Install the new or cleaned filter element on the spigot again by slightly rotating it.
- ▶ The filter is to be assembled in reverse order.
- ▶ The torque specifications (Tightening torques chapter) are to be observed.
- ▶ Commission the system.

 **WARNING!**

- | | |
|--|---|
| <ul style="list-style-type: none"> ▶ Assemble and disassemble only with depressurized system! ▶ Filter is pressurized! ▶ Remove the filter bowl only if it is not under pressure! ▶ Do not exchange the optical/mechanical maintenance indicator while the filter is under pressure! | <ul style="list-style-type: none"> ▶ If the flow direction is not considered during assembly, the filter element will be destroyed. Particle contaminates could enter the system and damage the downstream components. |
|--|---|

 **Notices:**

- ▶ All maintenance of the filter should be performed by trained specialists.
- ▶ Proper function and safety are only guaranteed if original Hengst filter elements and spare parts are used.
- ▶ Warranty becomes void if the delivered item is changed by the ordering party or third parties or improperly mounted, installed, maintained, repaired, used or exposed to environmental condition that do not comply with the installation conditions.

Tightening torques

(dimensions in mm [inch])

Mounting

Series 245...	LEN0040	LEN0063	LEN0100	LE0130	LE0150	LEN0160	LEN0250	LEN0400
Screw/tightening torque with $\mu_{\text{total}} = 0.14$	M6 / 4.5 Nm \pm 10%							
Quantity	4							
Recommended property class of screw	8.8							
Minimum screw-in depth	6 + 1 mm [0.24 + 0.04 in]							

Filter bowl and maintenance indicator

Series 245...	LEN0040	LEN0063	LEN0100	LE0130	LE0150	LEN0160	LEN0250	LEN0400
Tightening torque filter bowl	50 Nm + 10 Nm							
Tightening torque maintenance indicator	max. 50 Nm							
Tightening torque cubic connector screw switching element EN-175301-803	M3/0.5 Nm							

Directives and standardization

Product validation

Hengst filters, the filter elements built into them and filter accessories are tested and quality-monitored according to different ISO test standards:

Pressure pulse test	ISO 10771:2015-08
Filtration performance test (multipass test)	ISO 16889:2008-06
Δp (pressure loss) characteristic curves	ISO 3968:2001-12
Compatibility with hydraulic fluid	ISO 2943:1998-11
Collapse pressure test	ISO 2941:2009-04

The development, manufacture and assembly of Hengst industrial filters and Hengst filter elements is carried out within the framework of a certified quality management system in accordance with ISO 9001:2015.

Classification according to the Pressure Equipment

Directive

The inline filters for hydraulic applications according to 51421 are pressure holding equipment according to article 1, section 2.1.4 of the Pressure Equipment Directive 97/23/EC (PED). However, based on the exception in article 1, section 3.6 of the PEG, hydraulic filters are

exempt from the PED if they are not classified higher than category I (guideline 1/19).

The fluids from the chapter "Compatibility with approved pressure fluids" were considered for the classification.

They do not receive a CE mark.

Use in explosive areas according to directive 94/9/EC (ATEX)

The inline filters according to 51421 are no equipment or components in the sense of directive 94/9/EC and are not provided with a CE mark. It has been proven with the ignition risk analysis that these inline filters do not have own ignition sources acc. to DIN EN 13463-1:2009.

According to DIN EN 60079-11:2012, electronic maintenance indicators with a switching point:

WE-1SP-M12 x 1 **R928028409**

WE-1SP-EN175301-803 **R928036318**

are simple, electronic operating equipment that do not have an own voltage source. This simple, electronic operat-

ing equipment may - according to DIN EN 60079-14:2012 - in intrinsically safe electric circuits (Ex ib) be used in systems without marking and certification.

The inline filters and the electronic maintenance indicators described here can be used for the following potentially explosive areas:

	zone suitability	
Gas	1	2
Dust	21	22

Directives and standardization

Complete filter with mech./opt. Maintenance indicator			
Use /assignment		Gas 2G	Dust 2D
Assignment		Ex II 2G c IIC TX	Ex II 2D c IIC TX
Conductivity of the medium	pS/m	min	300
Dust accumulation		max	–
			0.5 mm

electronic switching element in the intrinsically safe electric circuit			
Use /assignment		Gas 2G	Dust 2D
Assignment		Ex II 2G Ex ib IIB T4 Gb	Ex II 2D Ex ib IIIC T100°C Db
perm. intrinsically safe electric circuits		Ex ib IIC, Ex ic IIC	Ex ib IIIC
Technical data		Values only for intrinsically safe electric circuit	
Switching voltage	Ui	max	150 V AC/DC
Switching current	li	max	1.0 A
Switching power	Pi	max	1.3 W T4 T _{max} 40 °C
		max	1.0 W T4 T _{max} 80 °C
Surface temperature ¹⁾		max	–
inner capacity	Ci		negligible
inner inductivity	Li		negligible
Dust accumulation		max	–
			0.5 mm

¹⁾ The temperature depends on the temperature of the medium in the filter and must not exceed the value specified here.

Possible circuit according to DIN EN 60079-14

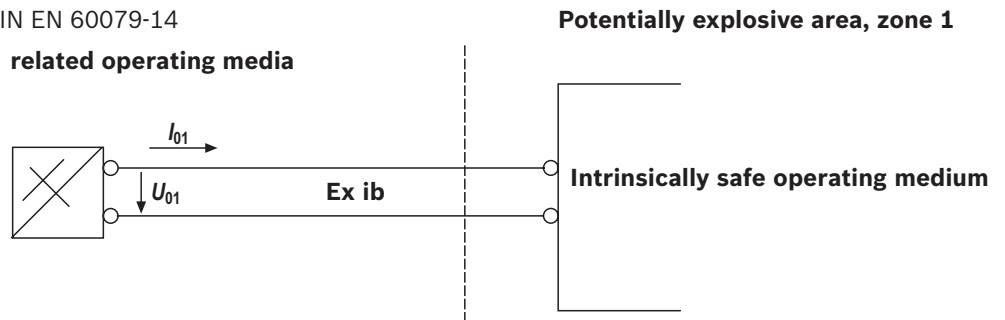

⚠ WARNING!

- ▶ Explosion hazard due to high temperature!
The temperature depends on the temperature of the medium in the hydraulic circuit and must not exceed the value specified here. Measures are to be taken so that in the explosive area, the max. admissible ignition temperature is not exceeded.
- ▶ When using the inline filters in accordance with 51 421 in potentially explosive areas, appropriate equipmental bonding has to be ensured. The filter is preferably to be grounded via the mounting screws. It has to be noted in this connection that paintings and oxidic protective layers are not electrically conductive.
- ▶ During filter element exchanges, the packaging material is to be removed from the replacement element outside the explosive area

👉 Notices:

- ▶ Maintenance only by trained specialists, instruction by the machine end-user acc. to DIRECTIVE 1999/92/EC appendix II, section 1.1
- ▶ Warranty is only applicable when using genuine Hengst spare parts

Notes

Hengst Filtration GmbH
Hardtwaldstr. 43
68775 Ketsch, Germany
Phone +49 (0) 62 02 / 6 03-0
hydraulicfilter@hengst.de
www.hengst.com

© This document, as well as the data, specifications and other information set forth in it, are the exclusive property of Hengst Filtration GmbH. It may not be reproduced or given to third parties without consent of Hengst Filtration GmbH. The data specified above only serve to describe the product. No statements concerning a certain condition or suitability for a certain application can be derived from our information. The information given does not release the user from the obligation of own judgment and verification. It must be remembered that our products are subject to a natural process of wear and aging.